

SilverMax™ 23 Frame X-Series

The SilverMax™ is a fully integrated Hybrid Servo Motor with feedback, a Controller/Indexer, and a Digital Driver in a compact package. All communications and power are accessed through a single 19 pin M16 connector. The interface includes 7 I/O, all of which support both LVTTTL and analog signals, and one of which also supports 0 to 10v analog input. A processor back-up power input and a hardware drive enable are also included. Communication via CANopen and RS-485 serial, which may be operated simultaneously. The driver is rated to 6A continuous per phase. The system is designed for use at +12.5 to +48 VDC.

System Overview

Point-to-Point Moves

- Relative or Absolute
- Velocity or Time Based
- S-Curve

Advanced Motion Profile Moves

- Profile Move Commands
- Register Based
 - Position/Accel/Decel/Vel
 - Modify On-the-Fly

Multi-Axis Linear Interpolation

- XYZ Coords Contained in Text File
- CANopen® used for local bus
- 1000+ Points Stored in NV Memory

Program and Data Storage

- 32K Non-Volatile Memory:
- 2000-3000 Program Lines
- User Data Examples
 - CAM Tables
 - Motion Profiles
 - Lookup Tables

Electronic Slip Clutch/Brake

- Variable Torque
- Wind/Unwind Applications

Anti-Hunt™

- Optionally use Open Loop While Holding
- No Servo Dither While at Rest

Communications

- RS-485 @ up to 230K Baud
- ASCII, Binary, Modbus®, DMX512
- Host Control While Servo in Motion
- CANopen® (Rev 03 SW and higher)

Programming Language

- Easy, Menu Driven Interface
- Command Parameter Prompts
- No Syntax Errors
- User Namable I/O and Registers

Advance PVIA™ Servo Loop

- 100:1 Inertial Mismatch
- Direct Drive Oversized Inertial Loads
 - Flywheels/Belt Drives
 - Typically Without Gearheads
- More Stable Than PID

Digital 4 Quadrant Vector Drive

- DSP Driven for Reduced Noise

Multi-Task/Multi-Thread

NEMA 23 Frame

- 8000 Counts/Rev Encoder
- Up to 280 oz-in (2 Nm)
(continuous)

Specifications	X23C-1	X23C-3	X23C-6	X23C-8
Maximum Speed (RPM)	4000	4000	2500	1000
48v Optimal Speed (RPM)	2500	1000	600	500
Torque (oz-in / Nm) at Optimal Speed	45 0.31	90 0.65	205 1.44	225 1.59
Continuous Stall Torque oz-in / Nm	75 0.53	170 1.20	300 2.11	380 2.68
Peak Power (Mech. Watts)	84	90	90	84
Rotor Inertia oz-in ² / Kg-m ²	0.82 1.5E-5	1.53 2.8E-5	3.28 6.00E-5	4.37 8.0E-5
Weight pounds / Kg	1.35 0.61	1.82 .82	2.97 1.35	3.41 1.55
Maximum Driver Input Current (Amps - DC)	4.0	4.0	4.0	4.5
Maximum Radial Force (lbs) / Newtons 0.79"/ 20mm from mounting face	16.8 75	16.8 75	16.8 75	16.8 75
Maximum Axial Force (lbs) / Newtons	3.4 15	3.4 15	3.4 15	3.4 15
Notes				Special Order

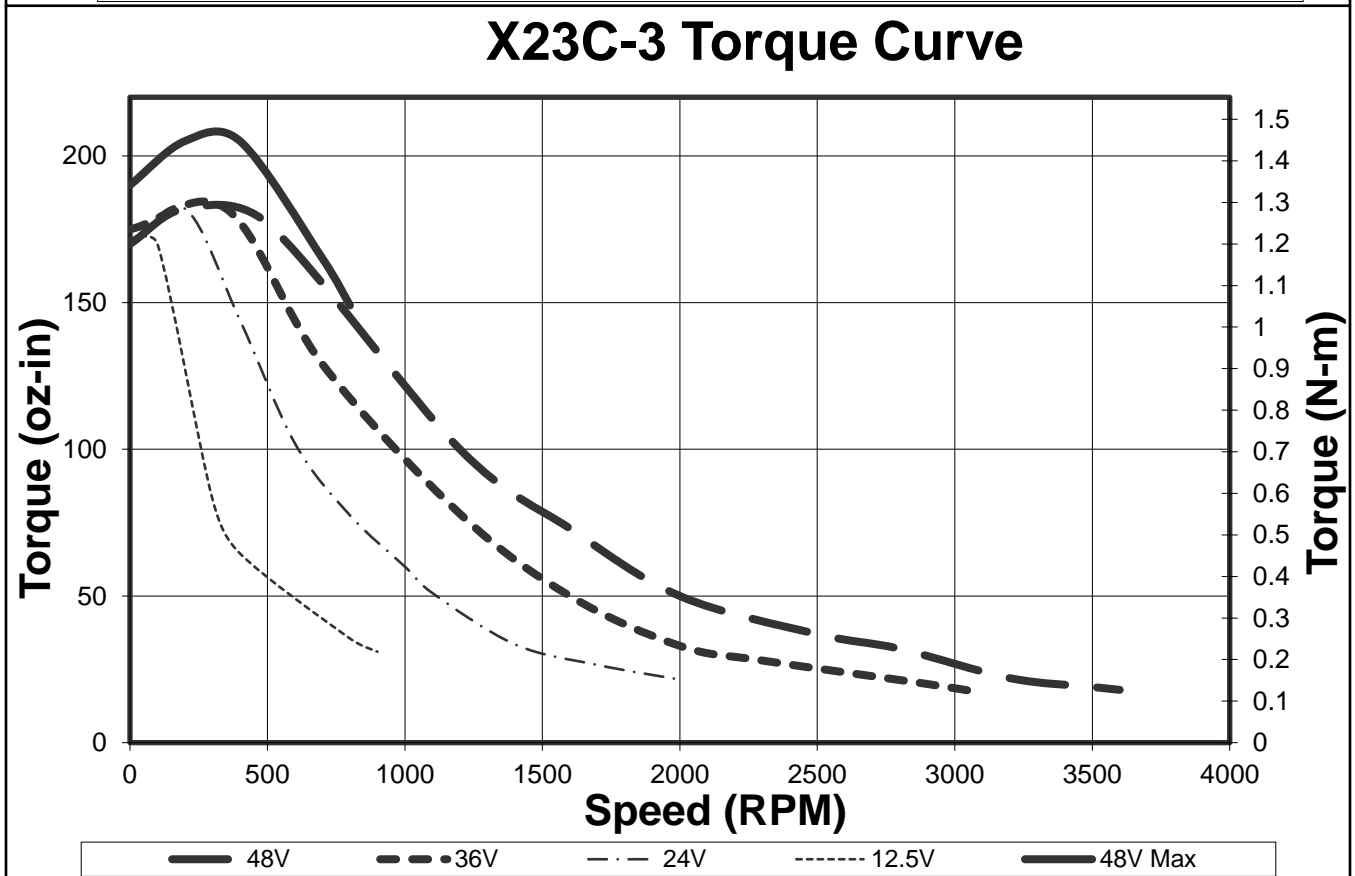
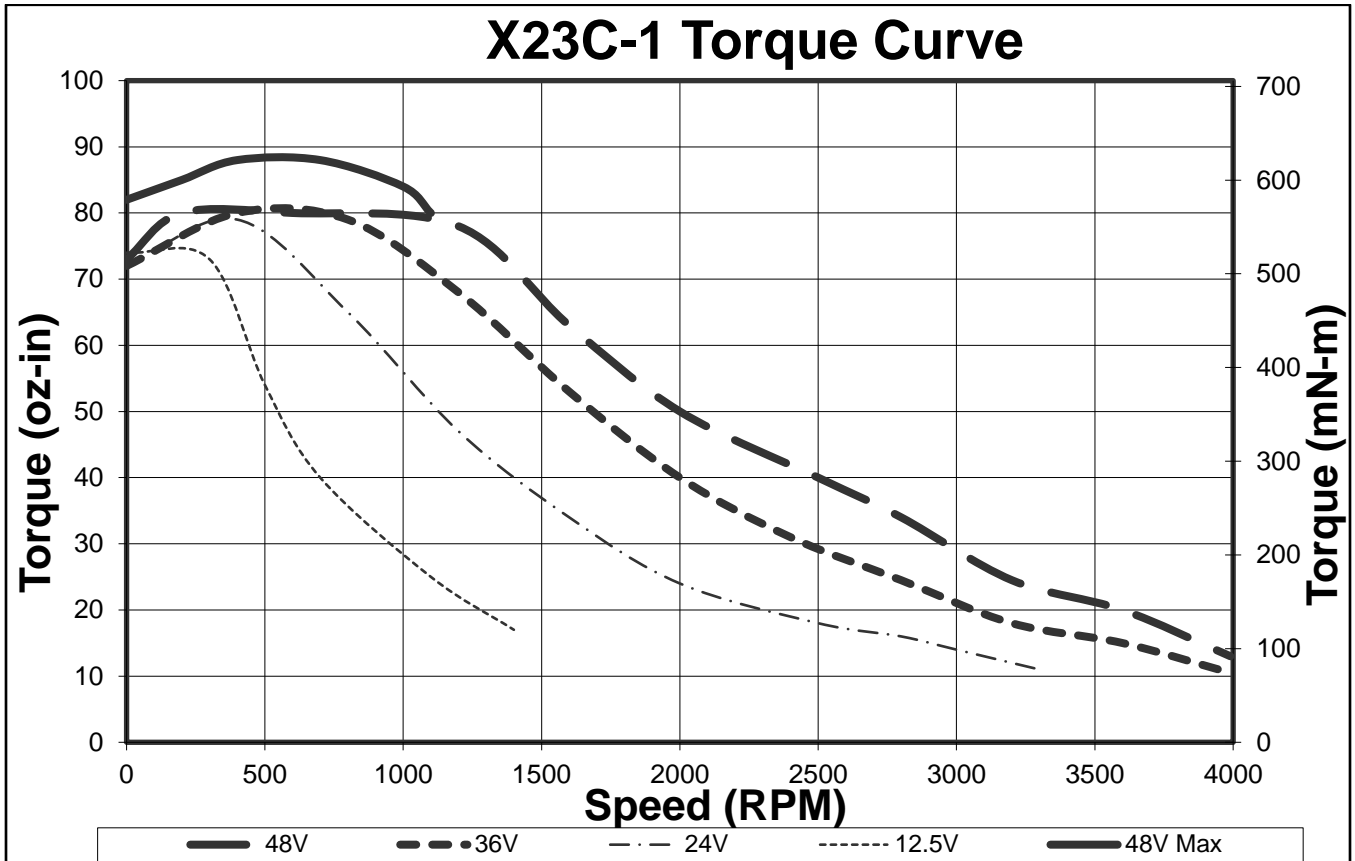

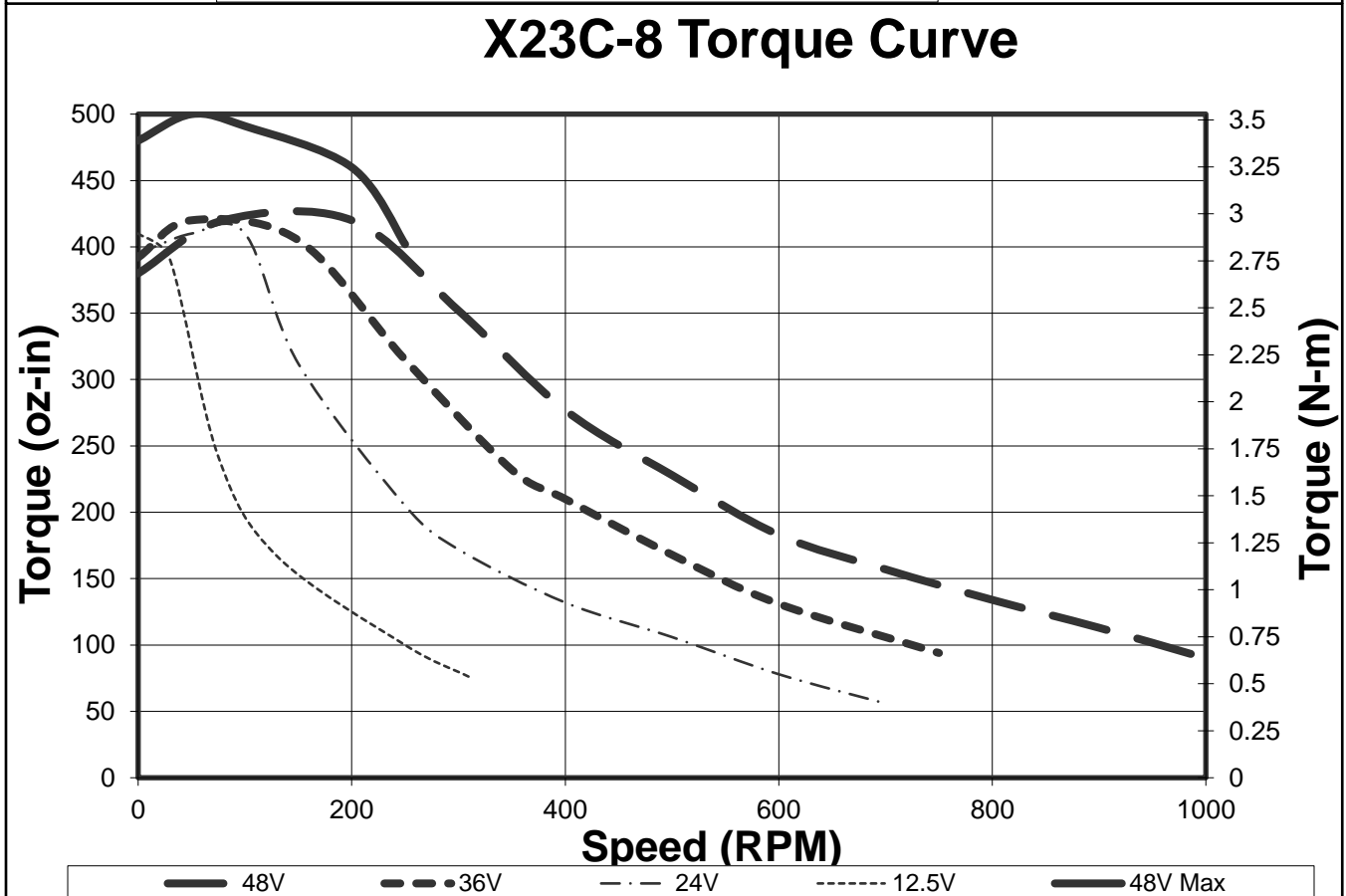
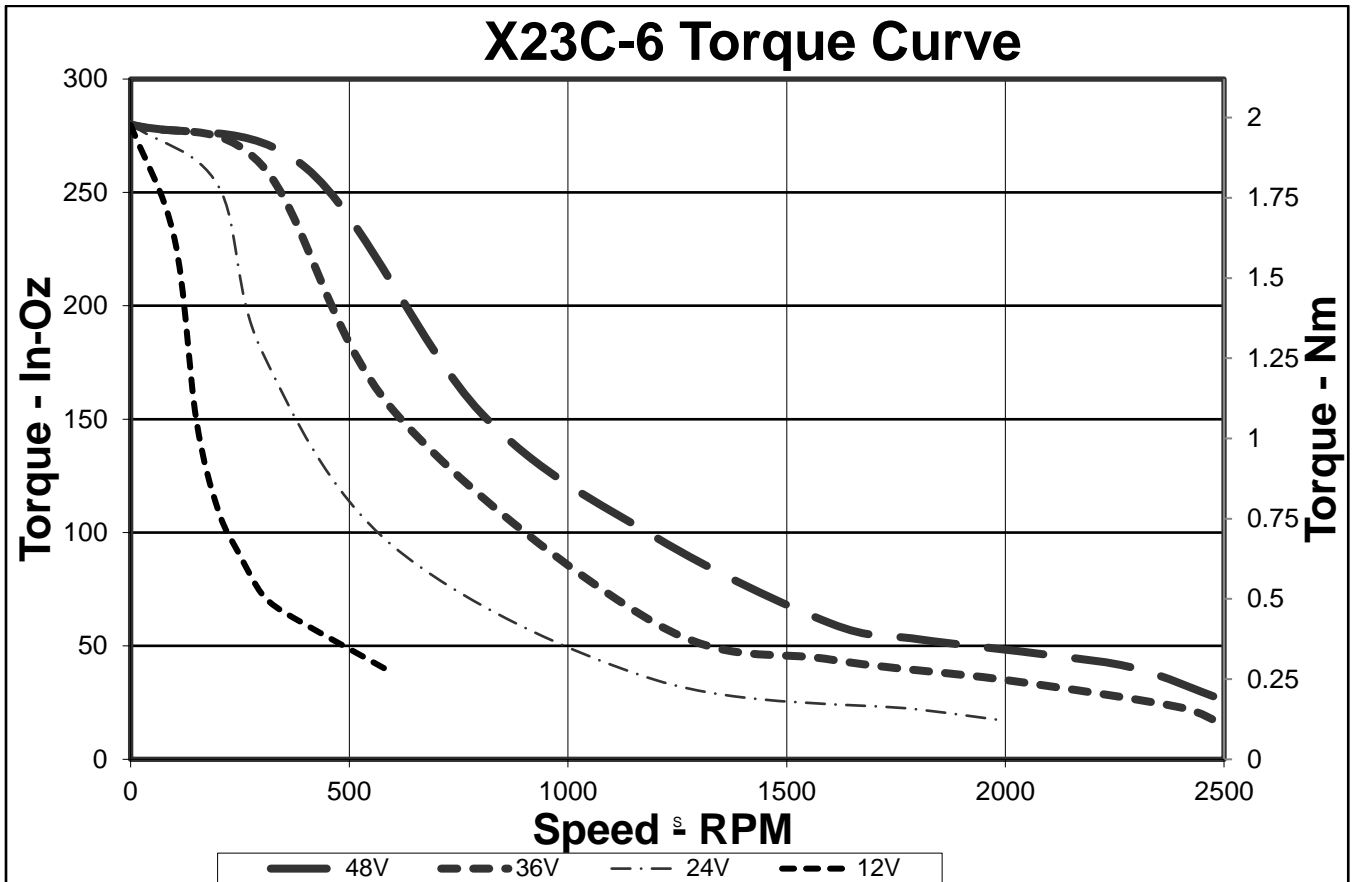

SilverMax X-series Interface (SMI)

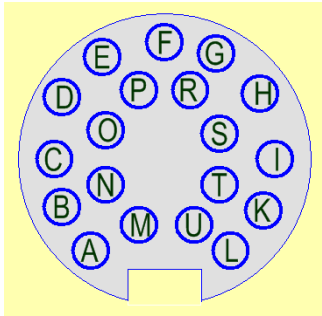

Pin	Signal
A	V+
B	V+
C	IO7
D	IO5
E	IO4
F	IO2
G	IO1
H	485A
I	CAN-L
K	PGND
L	PGND
M	Processor Power
N	Drive Enable
O	IO6
P	IO3
R	485B
S	Logic Ground
T	CAN-H
U	+5v

Input Power

Voltage

+12.5 VDC to +48 VDC, regulated. Device must be initialized for the actual operating voltage. An external clamp may be required if rapid decelerations of large loads are present. Both V+ pins and both PGND pins shall be used. The power circuit shall be fused at no more than 8A if the power supply is capable of more than 8 Amps. PGND is also connected to the frame of the controller/motor.

Processor Power

+8 VDC to +12 VDC. Separate processor power input. This input may be used to keep the processor running while the main input power is shut off, so as to be able to continue to track the encoder signals, etc. No connection is needed for normal operation.

Input Current

5.5 Amps maximum for any input voltage, +12.5 VDC to +48 VDC per controller. See particular motor size for details for that motor.

Inputs & Outputs

Digital Inputs

0 to +3.3 VDC. LVTTTL level compatible. All inputs have a light pull-up (~100k ohm to 3.3v). All I/O have an optional programmable pull-up/pull-down of 2.2 k ohm; the source to these resistors may also be floated if no pull-up or pull-down is needed. The seven IO are protected to +/- 40v.

Digital Output Voltage

0 / +3.3 VDC.

Digital Output Current

Sinking or Sourcing: 2mA

Analog Inputs

All 7 I/O may be used as Analog Inputs: 0 to +3.3 VDC input signal range.

IO7 has a secondary circuit to handle 0 to +10v input signal range; the input protection will isolate the normal 3.3 v input channel allowing the 0 to 10v operation.

Resolution: 12 bits (before filtering)

Analog signals are read every servo cycle (120 μ sec.) and the converted analog data is processed through a (default) 5 ms filter to reduce noise & transients.

Drive Enable Input

This hardware drive enable input must be connected to +10 VDC to +48 VDC for the drive electronics to operate.

Communications**Serial Interface**

RS-485 multi-drop, Reduced unit load accommodates up to 255 nodes.

Protected up to +/- 70v.

Note: RS-485 requires a nominal 120 ohm $\frac{1}{2}$ W termination resistor at each end of the network for longer runs. This termination is not provided onboard and must be provided by the user.

Protocols

8-bit ASCII, 9-bit binary, Modbus®, and DMX512

Hardware Configuration Settings

Available Baud Rates: 2400, 4800, 9600, 19.2k, 28.8k, 57.6k, 115.2k or 230.4k
(250k only for DMX512)

Data Bits: 8 (9 bits for binary)

Stop Bits: 1.5 or 2

Parity Bit: None (Modbus supports None, Even, Odd)

CAN interface

The CAN bus connection is not isolated, but does include transceivers which have an extended +/- 80v fault protection range. The CANopen® communications protocol allows the unit to function as a master, slave, or peer on a CANopen network. See the CANopen User Manual for details on the CANopen protocol. This protocol operates simultaneously and independently from the standard serial protocols.

Note that a 120 ohm $\frac{1}{2}$ W termination resistor is required at each end of the CAN network (only two per system). This termination is not provided onboard the controller and must be provided by the user. For the CAN bus, this termination is **not** optional.

CANopen® and CiA® are registered community trademarks of CAN in Automation e.V.

LED Lights

Two LED lights are provided on the back of the SilverMax. The COMM LED (normally Red) indicates the unit is ready (no program running) by a dim level, it is off between communications if a program is running. It blinks brightly during each incoming communications frame. The Status light (normally Green) varies in intensity with the motor torque (negative torque dimmer, positive torque brighter); if Enable Done Bit is configured the Status LED lights to indicate Program Done (see Enable Done High and Enable Done Low commands). Status LED is also used to blink error codes if a fault is detected and the Enable Done bit is not configured.

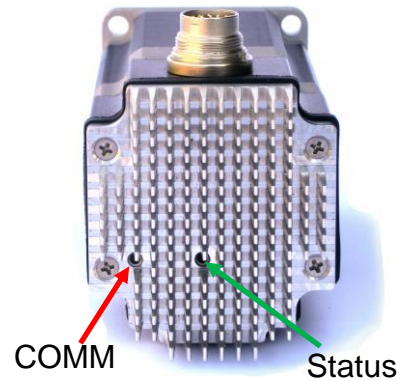

Internal Temperature Sensor

Reported temperature readings is of the internal CPU’s junction temperature, which is about 25C higher than case temperature, once temperatures have stabilized. The CPU’s maximum temperature is 125C. Previous controller designs used a separate temperature sensor that measured ambient temperature.

Environmental Specifications

Operational Temperature

-10 C to +70 C. Continuous torque curves taken at 20C; derating may be needed at higher temperatures. 100% torque requires motor affixed to thermally conductive structure, and may need air flow.

Storage Temperature

- 40 C to +85 C

Humidity

Continuous specification is 95% RH non-condensing.

Shock

Limitation is approximately 50g/11ms.

Specifications subject to change without notice. See www.QuickSilverControls.com for current information.

Mechanical Dimensions

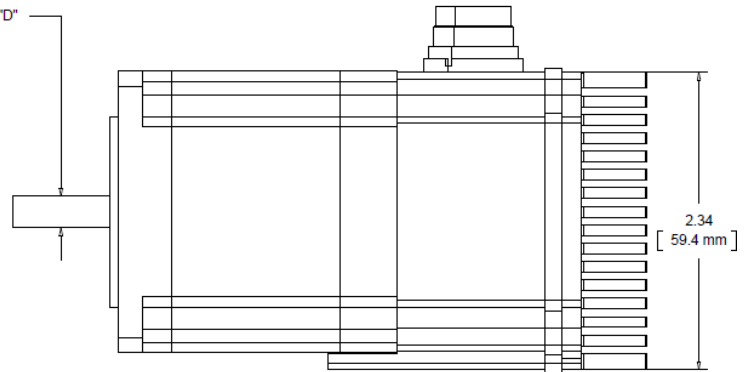
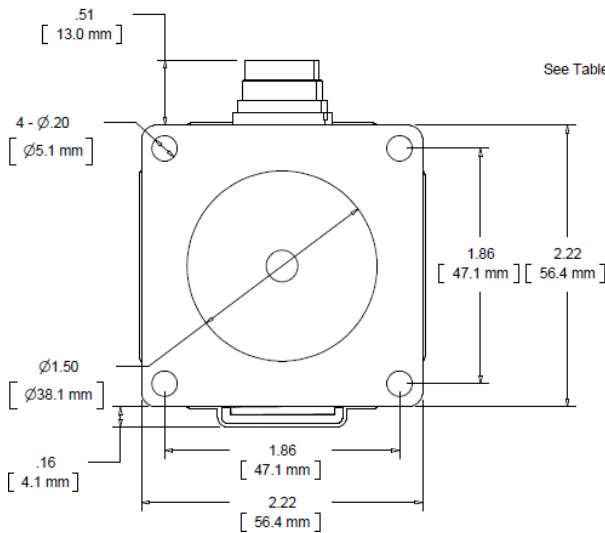
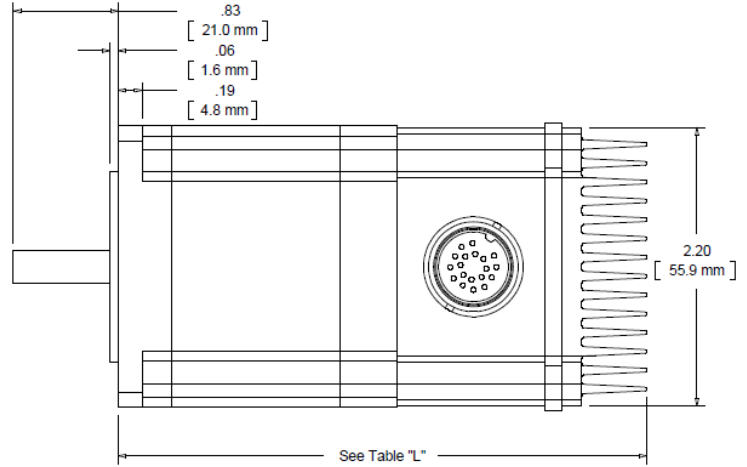
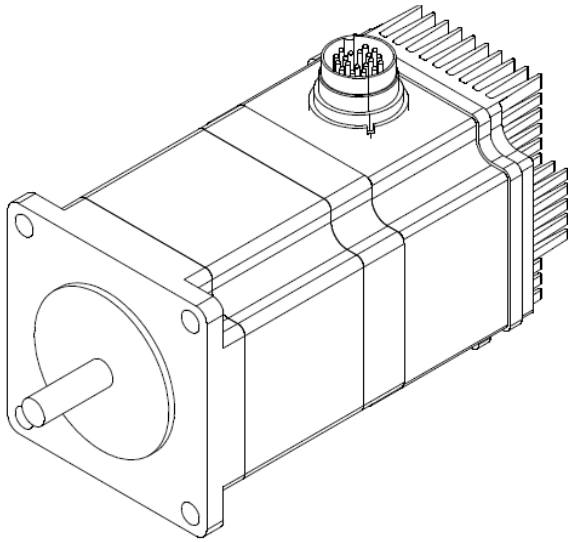

Model	Shaft Diameter "D"		Body Length "L"	
QCI-X23C-1	0.25 in	6.35mm	3.58 in	91 mm
QCI-X23C-3	0.25 in	6.35mm	4.17 in	106 mm
QCI-X23C-6	0.315 in	8 mm	5.2 in	132 mm
QCI-X23C-8	0.315 in	8 mm	6.38 in	162 mm

Recommended Components

SilverMax X-series Start-Up Materials

For first time users, QCI recommends purchasing the following items to aid with use of the SilverMax X-series servo motor:

- 4' SilverMax X-series Interface Cable (QCI-XC-SMI-04)
- Breakout Board X-series (QCI-BO-X1)
- USB to RS485 converter (QCI-USB-RS485)
- Desired QCI SilverMax X-series servo motor

Optionally:

- 240W, +48V Power Supply (SP-240-48)
- Power Supply Cord w/ Flying Leads (QCI-C-ACP-FLY-6)

Configuration Software: QuickControl™ is free and available from our website.

Typical System Setup

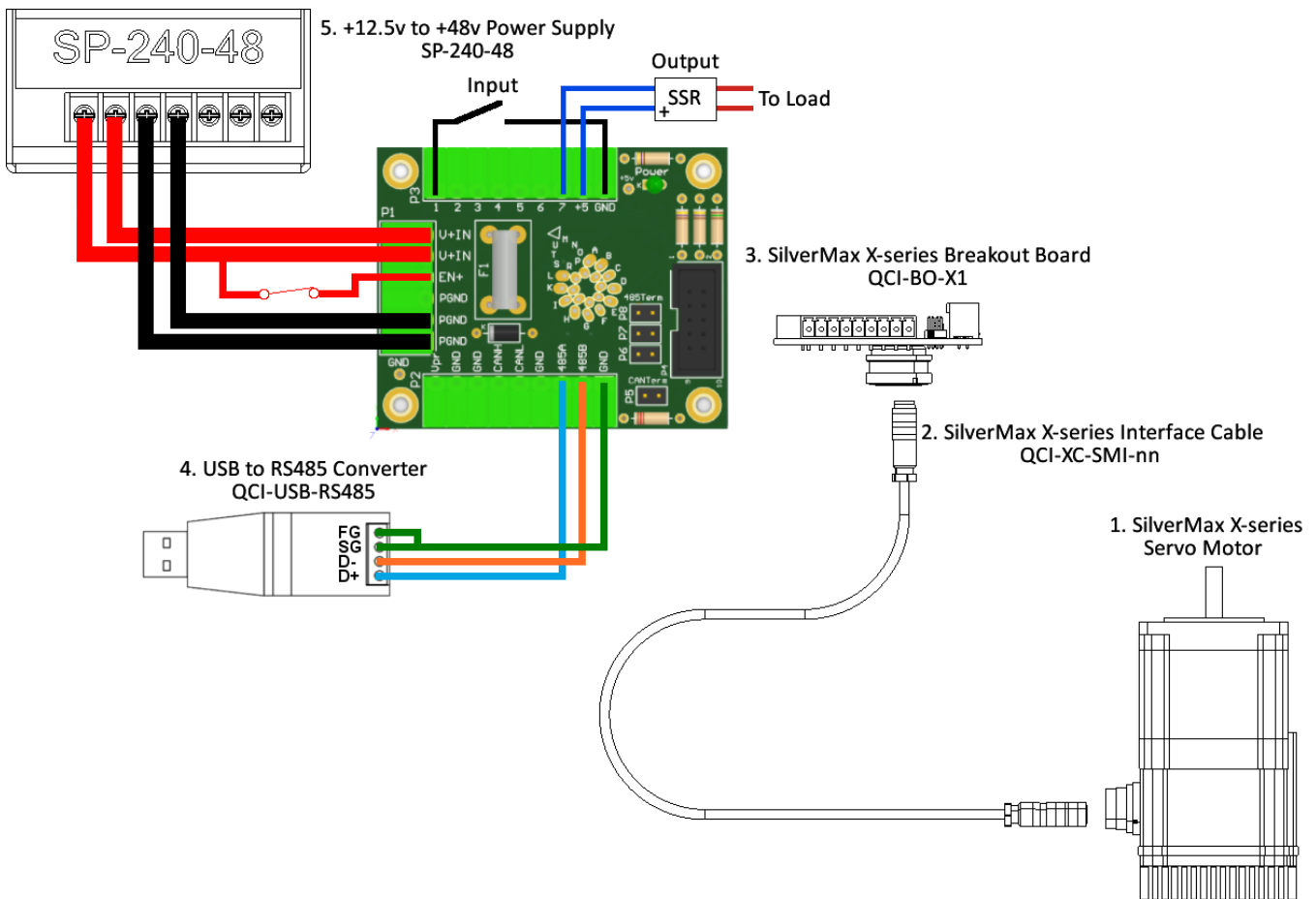

1. SilverMax X-series Servo Motor

Motor size based on application requirements.

2. SilverMax X-series Interface Cables

The QCI-XC-SMI-nn is used to connect the SilverMax X-series motor to the QCI-BO-X1 breakout board. Replace the last two digits “nn” with length of cable in feet (i.e. –10 for 10 feet). Standard lengths are 4 and 10 feet.

The QCI-XC-SMF-nn cable connects to the SMI connector on the SilverMax and provides a pig-tail to allow landing the various signals to your own terminating blocks – see [QCI-TD081](#) for more details.

3. SilverMax X-series Breakout (QCI-BO-X1)

QCI recommends purchasing a breakout to simplify wiring power, RS-485 communication, CAN, power backup, drive enable, and 7 LVTTTL I/O. The breakouts connect to the SilverMax Interface Cable and includes power fusing. The QCI-BO-X1 is designed to mount through the control housing, providing an IP67 seal for the control housing. See [QCI-TD079](#) for more information.

4. USB to RS485 Converter

USB-RS-485 converter provides a USB powered serial port with RS-485 signaling. See [QCI-TD073](#) USB-RS485 Converter Setup Guide for information on network termination and shielding recommendations.

5. Power Supply

Power supply selection is motor dependent, but the following will work with all SilverMax X-series 23 frame motors.

SP-240-48 (48V, 5A, 240 Watt)

6. External Regenerative Clamp (not shown)

Rapid deceleration of larger loads may require a Clamp circuit if the capacitors in the power supply output are not sufficient to hold the recovered energy. Continuous braking of a load also may require the Clamp to handle the generated power. See [QCI-TD017](#) for more information.

QCI-CLCF-04-R2

Part Numbers

SilverMax X - Series NEMA 23	
Motor Size	Standard: 8000 CPR Encoder 12.5v to 48v Driver Enable CANopen RS-485 – multiple protocols 19 pin M16 Connector
QCI-X23C-1	
QCI-X23C-3	
QCI-X23C-6	
QCI-X23C-8	

Contact Information

QuickSilver Controls, Inc.
990 N Amelia Ave
San Dimas, CA 91773
+1 (909) 599-6291 or (888) 660-3801
+1 (909) 599-6289 FAX
www.QuickSilverControls.com